

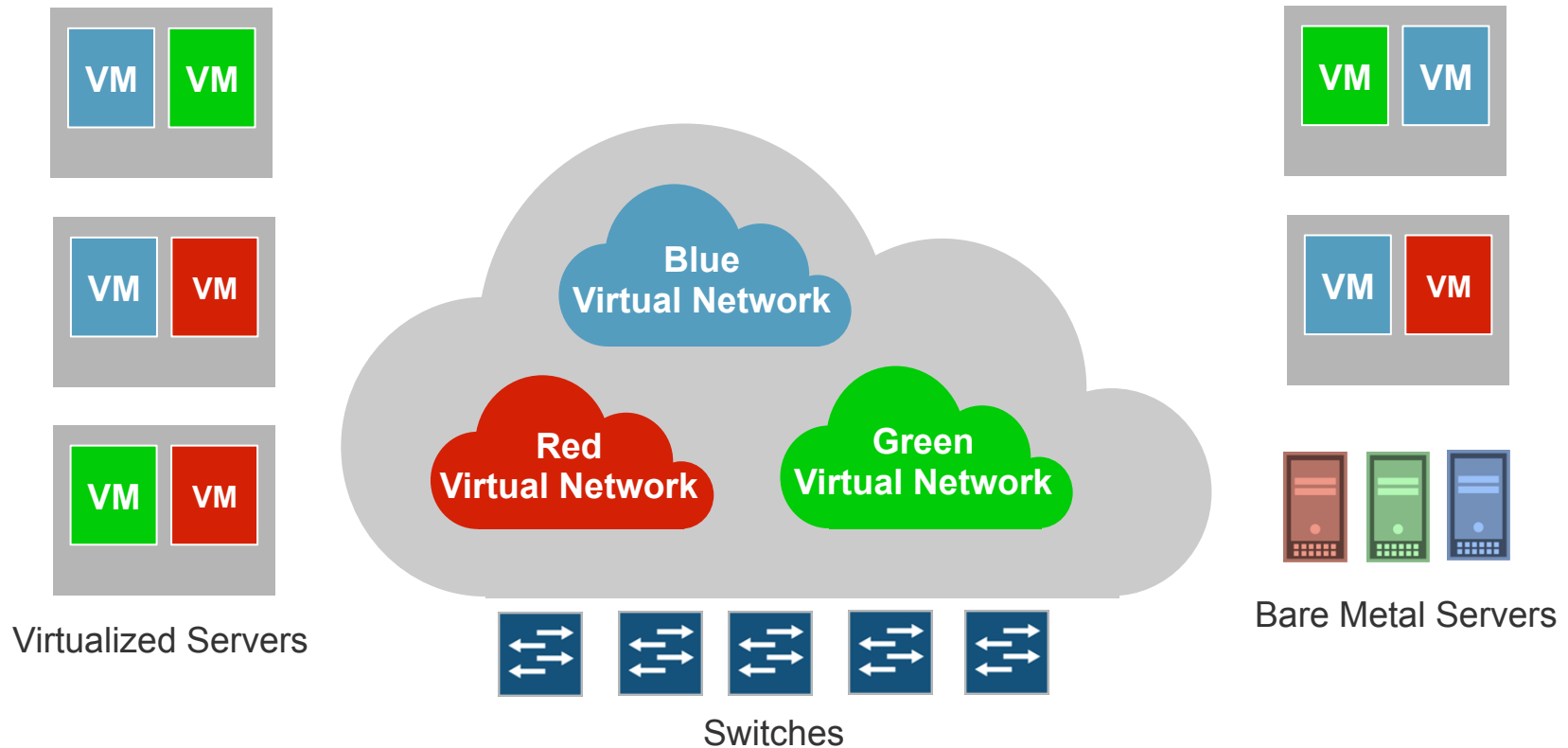

Marcio Pilotto
Gerente de Engenharia de Sistemas
Juniper Networks

Network Virtualization



Dynamic Network Virtualization at Scale

Without the complexity, scaling limitations, and stability issues of VLANs

Virtual Network Policies

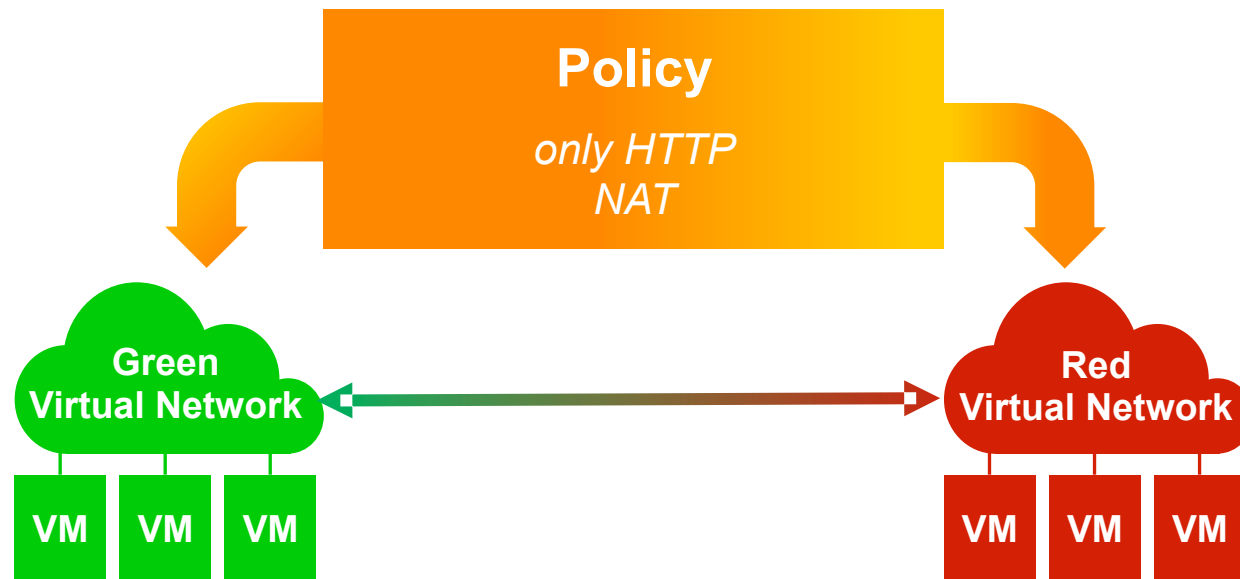

Virtual Network Policies

At a high level of abstraction, applied at the boundaries of virtual networks.

Service Chaining

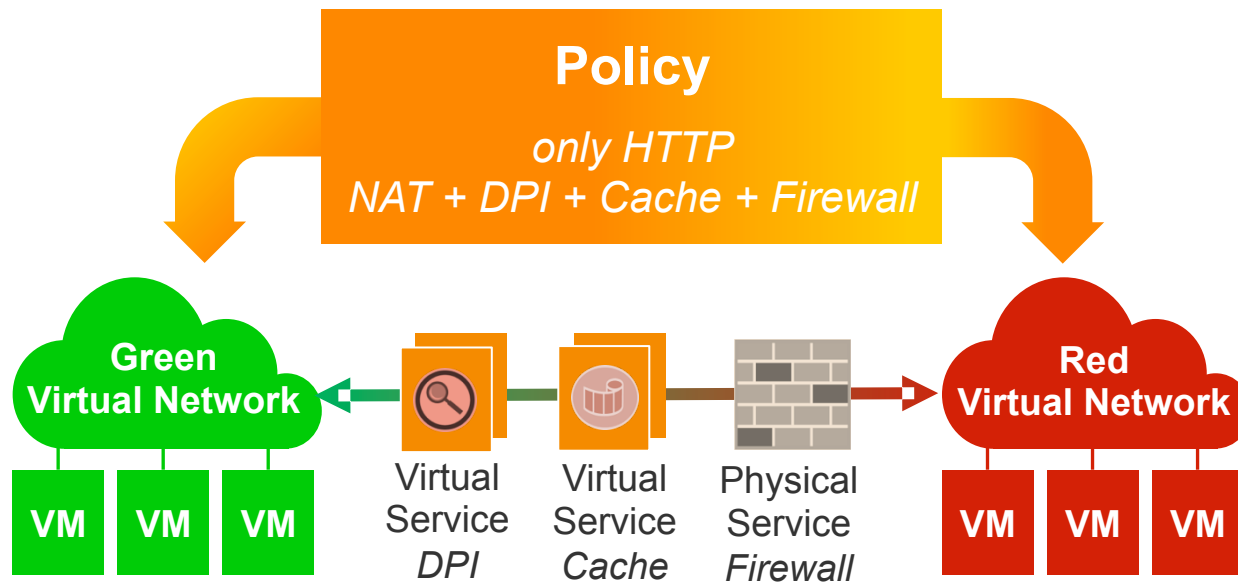

Service Chaining

Policy based application of virtual and physical services with scale-out.

Firewall, Intrusion Prevention, Load balancer, Cache, WAN optimizer, proxy, ...

Network Virtualization

Logical Abstraction

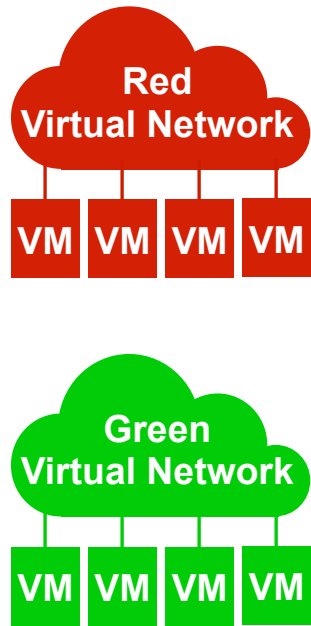

Physical Realization

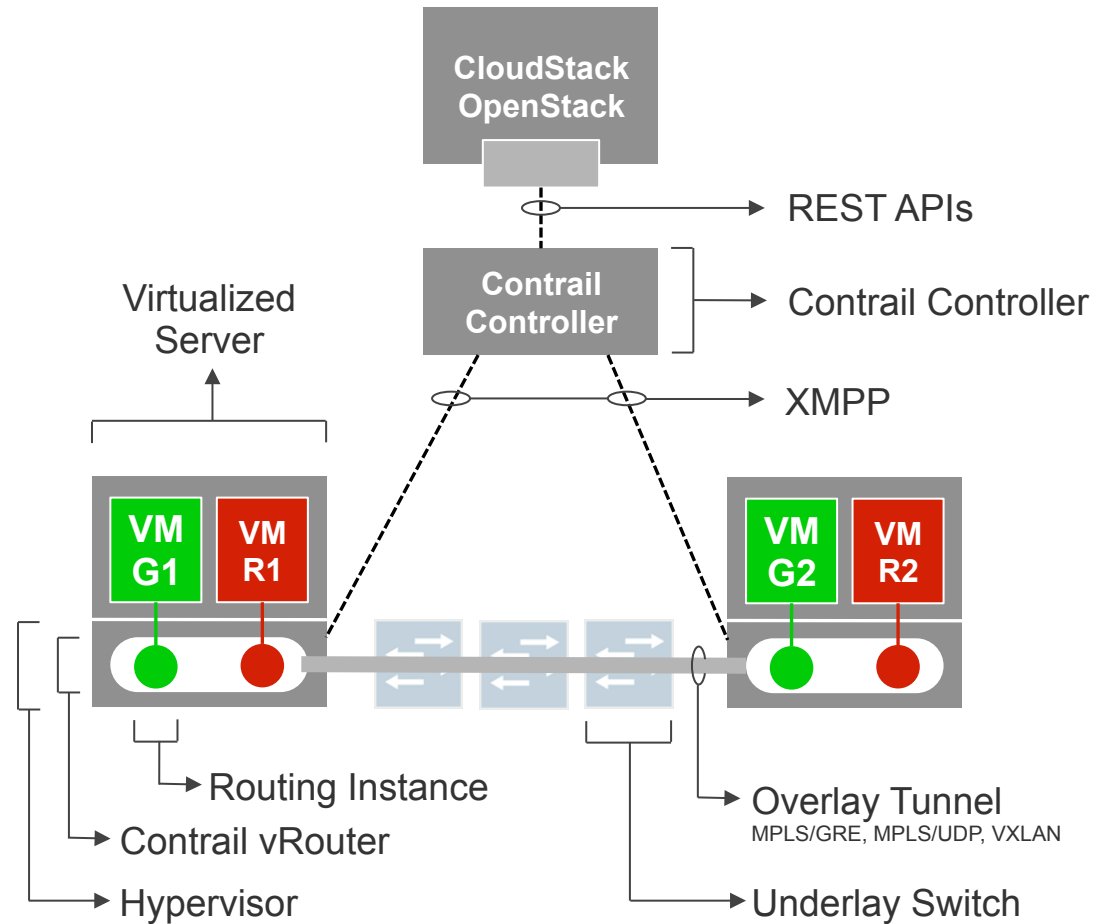

Gateway to Bare Metal Server

Logical Abstraction

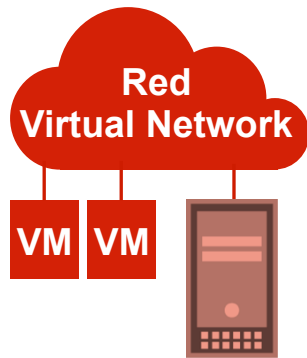

Physical Realization

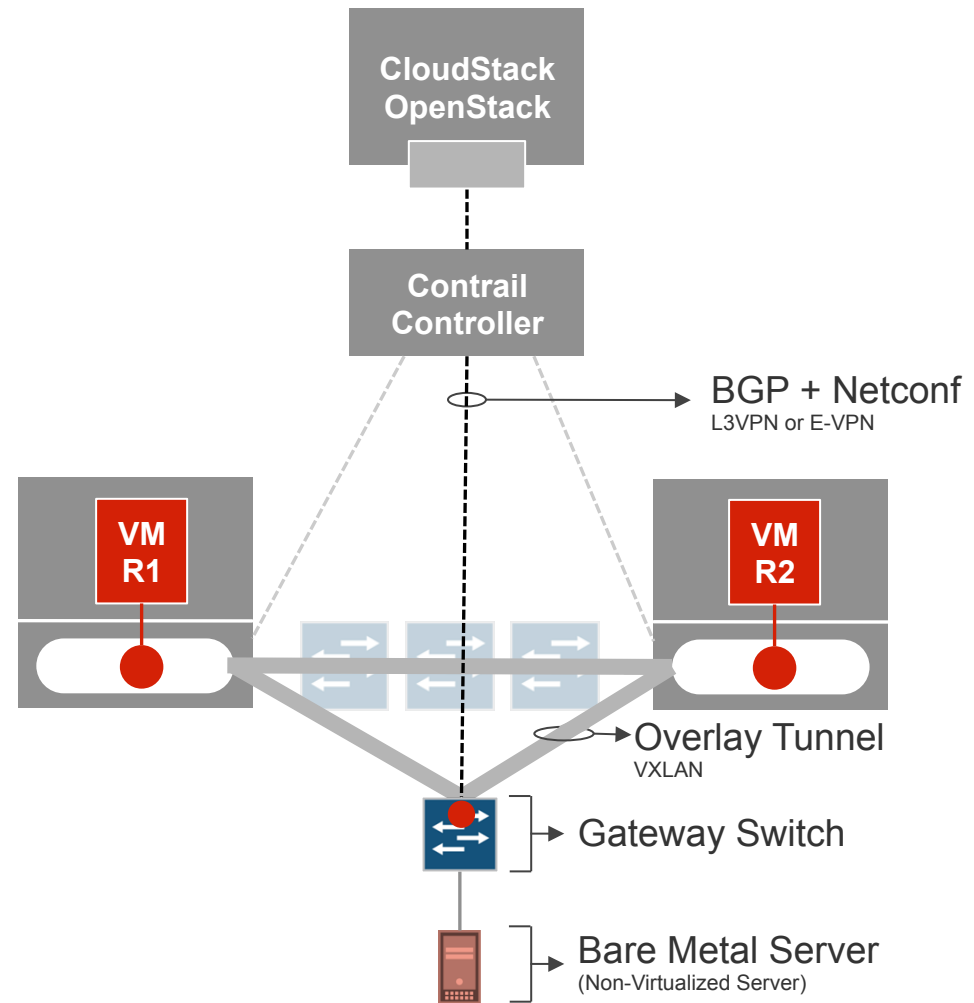

BMS INTEGRATION

Phy + Virt Interconnect

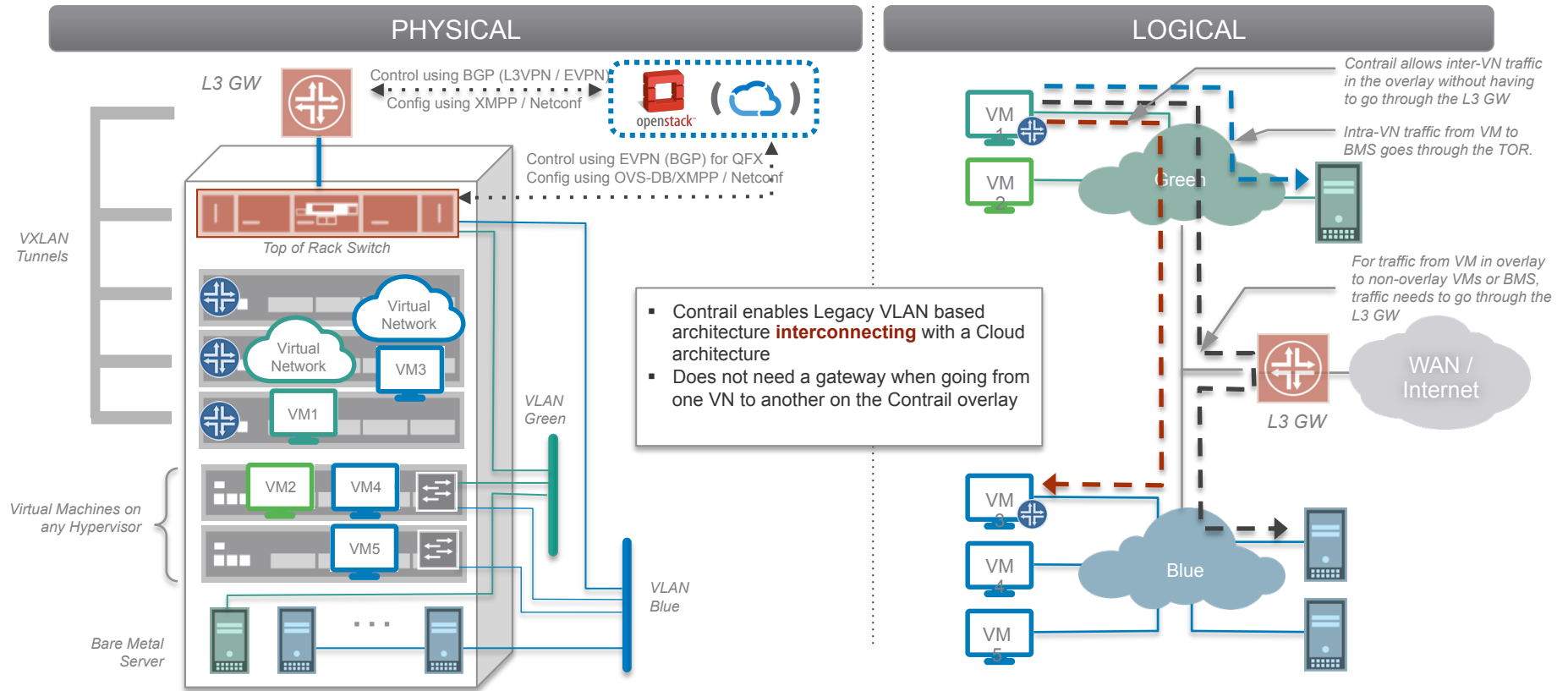

SDN as a Compiler

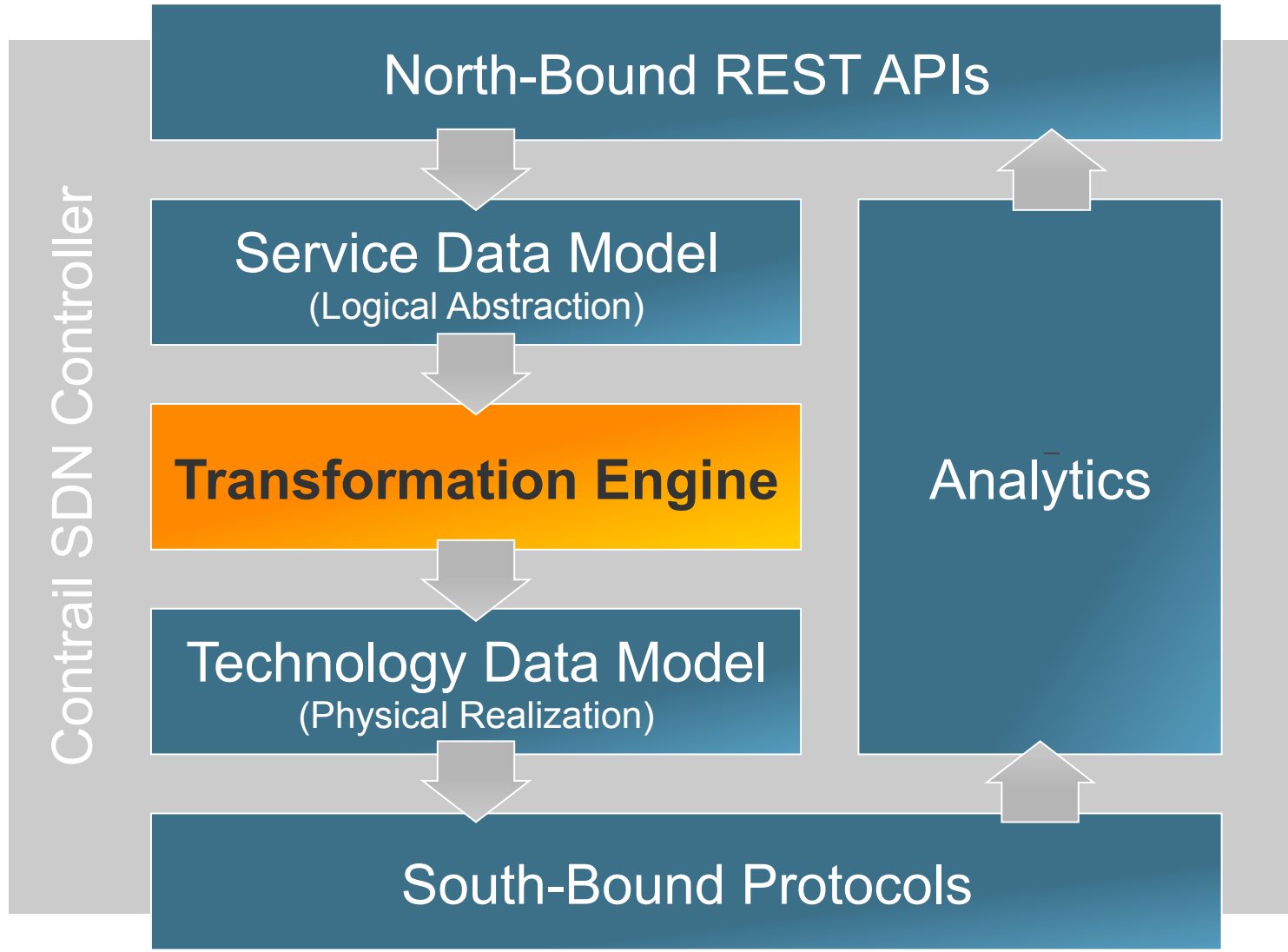

Highly Available Scale-Out

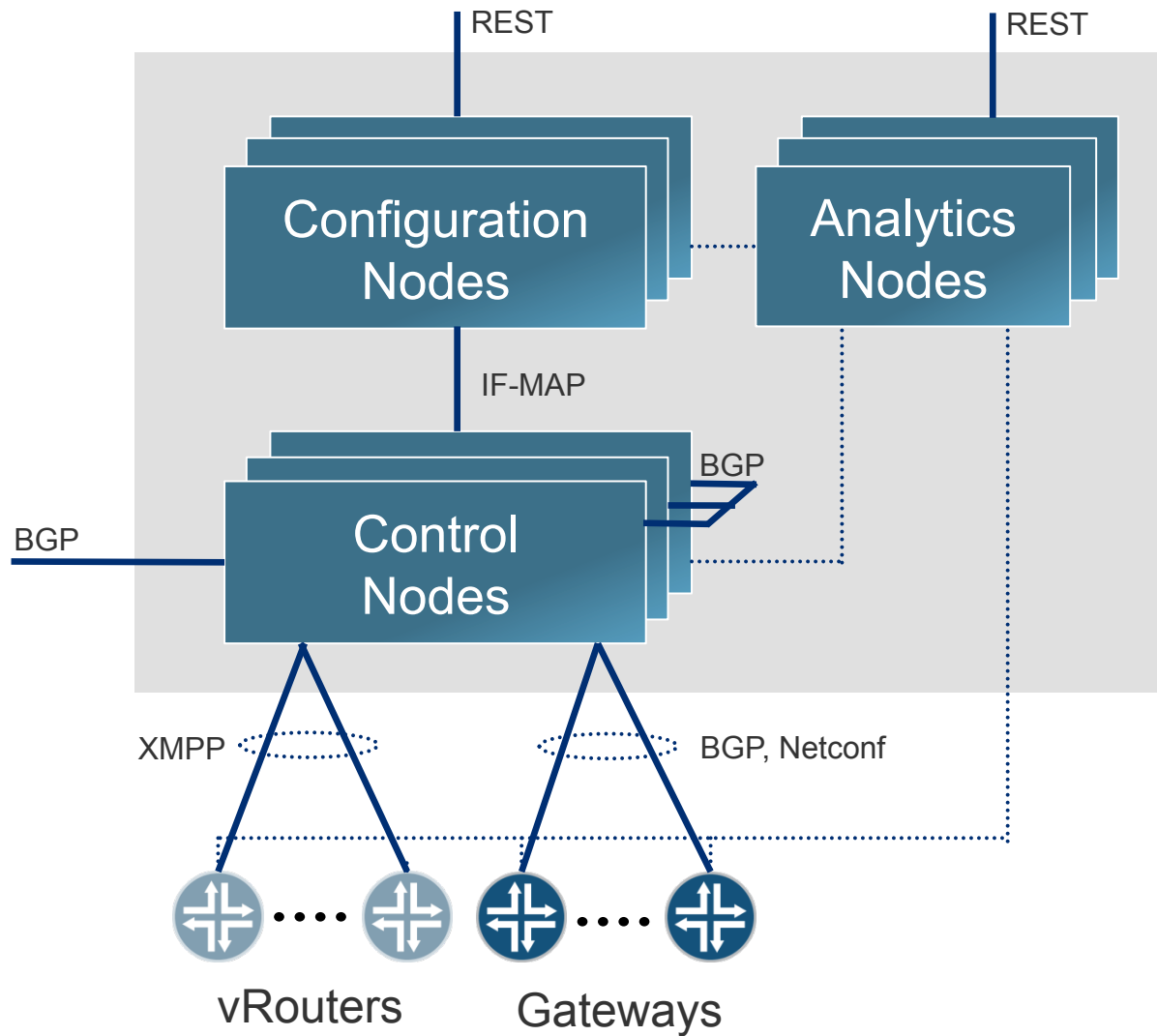

Logically Centralized
(Physically Distributed)

Horizontally Scalable

Highly Available
(Active-Active)

Federated

() **OPENCONTRAIL**

- Internet Scale Technology Applied to the Cloud
- Massively Scalable
- Standard Proven Technologies, Multi-Vendor
- Network Virtualization
- Virtual Network Policies
- Service Chaining
- Cloud Interconnect
- Seamless Integration with Physical Network
- Integrated Rich Analytics

opencontrail.org